

VX3000 & VX3000 H

Three instruments unit

VX3000 with three instruments table (right)

REF 8115-3000-01

VX3000 with three instruments table (left)

REF 8115-3000-02

VX3000 H with electric elevation table (right)

REF 8115-3000-11

VX3000 H with electric elevation table (left)

REF 8115-3000-12

- > Rotary table
- > Available in RIGHT or LEFT handed version
- > Table for 3 instruments with manual rotation and manual sliding working position
- > Electro mechanic locking system for table in any position
- > Console with touch screen control panel + hand instruments support
- > Column with adjustable led lamp and projector support plate
- > Electric elevation chair
- > Reclining back rest
- > Removable arm rest and foot rest



Lenses Tray

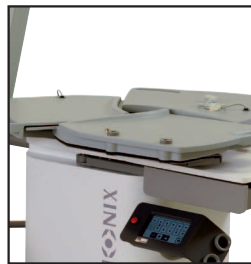

Three instruments table



Technical specifications

Dimensions	1600 X 1750
Weight	250
Seat up/down	•
Height of the seat (mm)	530 - 720 mm
Table up/down	H Model
Height of the Table VX3000	890 mm
Height of the table version H	765 - 900 mm
Seat backward - forward	Option
Seat rotation	180°
Back rest inclinasion	•
Armrest	•
Footrest	•
Removable armrest	•
Removable footrest	•
Voltage	230Vac 50 Hz (230Vac 60Hz - 110Vac 60Hz)
Working table voltage	Instrument 1 = 12 V / Instrument 2 = 220 V Instrument 3 = 220 V
Standards	ISO 9001:2008 - ISO 13485:2012

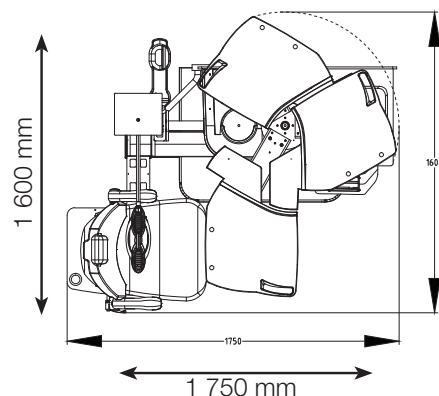
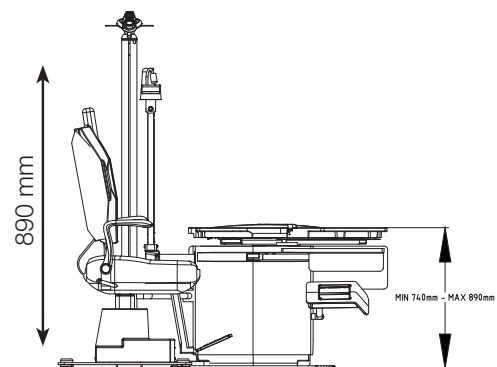

VX2000 & VX2000 H

Comfortable trendsetter unit

VX2000 with two instruments table (right)

REF 8115-2000-01

VX2000 with two instruments table (left)

REF 8115-2000-02

VX2000 H with electric elevation table (right)

REF 8115-2000-11

VX2000 H with electric elevation table (left)

REF 8115-2000-12

- > Available in RIGHT or LEFT handed version
- > Sliding table for 2 instruments
- > Electro mechanic locking system for table in any position
- > Console with touch-screen control panel + hand instruments support
- > Drawer
- > Column with adjustable led lamp and projector support plate
- > Electric elevation chair
- > Reclining back rest
- > Removable arm rest and foot



Control panel



Drawer accessories

Technical specifications

Dimensions	1600 X 1850
Weight	220
Seat up/down	•
Height of the seat (mm)	530 - 720 mm
Table up/down	H Model
Height of the Table VX3000	870 mm
Height of the table version H	725 - 860 mm
Seat backward - Forward	Option
Seat rotation	•
Back rest inclinasion	•
Armrest	•
Footrest	•
Removable armrest	•
Removable footrest	•
Voltage	230Vac 50 Hz (230Vac 60Hz – 110Vac 60Hz)
Working table voltage	Instrument 1 = 12 V / Instrument 2 = 220 V
Standards	ISO 9001:2008 - ISO 13485:2012

